

uzavřený se zápusťnou hlavou

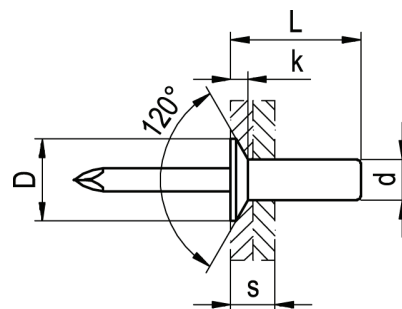

**Materiál: dřík - hliník AlMg5**  
**trn - ocel zinkovaná**

| d<br>mm | vrtání<br>mm | L<br>mm | s<br>mm     | D<br>mm | k<br>mm | tah<br>N | střih<br>N | balení<br>ks | tt-číslo      |
|---------|--------------|---------|-------------|---------|---------|----------|------------|--------------|---------------|
| 3,2     | 3,3          | 7,5     | 1,5 – 3,0   | 6,0     | 1,3     | 1240     | 1070       | 1000         | 21 231 32.071 |
|         |              | 9,0     | 3,0 – 4,5   |         |         |          |            |              | 21 231 32.091 |
|         |              | 10,5    | 4,5 – 6,0   |         |         |          |            |              | 21 231 32.101 |
|         |              | 12,0    | 6,0 – 7,5   |         |         |          |            |              | 21 231 32.121 |
|         |              | 13,5    | 7,5 – 9,5   |         |         |          |            |              | 21 231 32.131 |
| 4,0     | 4,1          | 9,5     | 2,5 – 4,5   | 7,5     | 1,7     | 2240     | 1710       | 500          | 21 231 40.091 |
|         |              | 11,0    | 4,5 – 6,5   |         |         |          |            |              | 21 231 40.111 |
|         |              | 12,5    | 6,5 – 8,0   |         |         |          |            |              | 21 231 40.121 |
|         |              | 14,0    | 8,0 – 9,5   |         |         |          |            |              | 21 231 40.141 |
| 4,8     | 5,0          | 9,5     | 3,0 – 4,5   | 9,0     | 2,0     | 3070     | 2230       | 500          | 21 231 48.091 |
|         |              | 11,0    | 4,5 – 6,0   |         |         |          |            |              | 21 231 48.112 |
|         |              | 12,5    | 6,0 – 7,5   |         |         |          |            |              | 21 231 48.121 |
|         |              | 14,0    | 7,5 – 9,0   |         |         |          |            |              | 21 231 48.142 |
|         |              | 15,5    | 9,0 – 10,5  |         |         |          |            |              | 21 231 48.151 |
|         |              | 19,0    | 10,5 – 14,0 |         |         |          |            |              | 21 231 48.191 |